

Chapter 3.4 - Measures of Relative Standing
z Scores and Percentiles

Consider a population of people

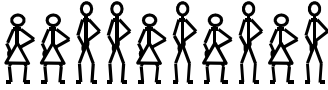

Line them up against the wall in size place and look down on them.

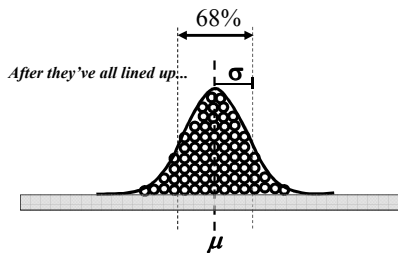
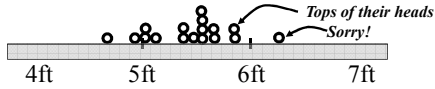

Chapter 3.4 - z Scores and Percentiles

In John's first exam, the class average was 80 and std dev was 5
Class Exam 1: $\mu = 80$ $\sigma = 5$

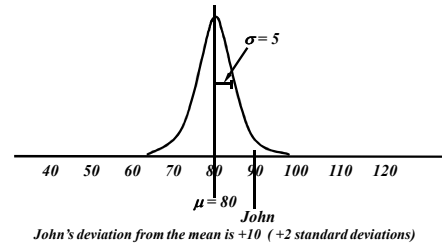

In John's second exam, the class average was 80 and std dev was 10
Class Exam 2: $\mu = 80$ $\sigma = 10$

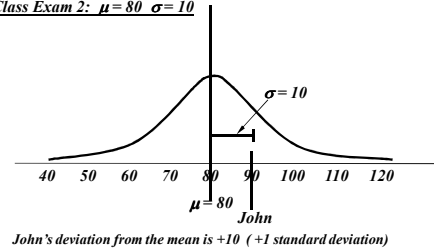

Chapter 3.4 - z Scores and Percentiles

Class Exam 1: $\mu = 80$ $\sigma = 5$

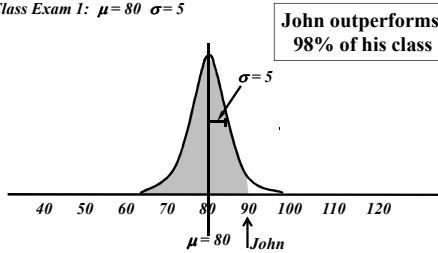

John's deviation from the mean is +10 (+2 standard deviations)

Class Exam 2: $\mu = 80$ $\sigma = 10$

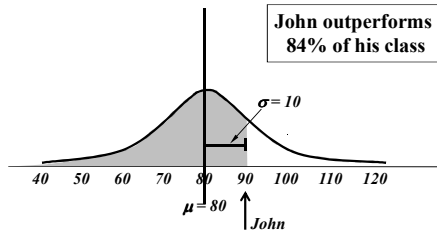

John's deviation from the mean is +10 (+1 standard deviation)

Chapter 3.4 - z Scores and Percentiles

Converting Raw Scores to z-scores

$$Z = \frac{X - \mu}{\sigma}$$

Exam	Mean (μ)	Standard Deviation (σ)	Matthew's Grade
Sociology	90	5	85
Communication	72	5	82
Philosophy	77	10	77

$$Z_{\text{sociology}} = \frac{X - \mu}{\sigma}$$

$$Z_{\text{communication}} = \frac{X - \mu}{\sigma}$$

$$Z_{\text{philosophy}} = \frac{X - \mu}{\sigma}$$

Chapter 3.4 - z Scores and Percentiles

Converting Raw Scores to z-scores

$$Z = \frac{X - \mu}{\sigma}$$

Exam	Mean (μ)	Standard Deviation (σ)	Matthew's Grade
Sociology	90	5	85
Communication	72	5	82
Philosophy	77	10	77

$$Z_{\text{sociology}} = \frac{X - \mu}{\sigma} = \frac{85 - 90}{5} = \frac{-5}{5} = -1$$

$$Z_{\text{communication}} = \frac{X - \mu}{\sigma} = \frac{82 - 72}{5} = \frac{10}{5} = +2$$

$$Z_{\text{philosophy}} = \frac{X - \mu}{\sigma} = \frac{77 - 77}{10} = \frac{0}{10} = 0$$

Chapter 3.4 - z Scores and Percentiles

Converting z-scores to raw scores

$$X = z\sigma + \mu$$

Exam	Mean (μ)	Standard Deviation (σ)	Jennifer's Z-score
Sociology	90	5	0
Communication	72	5	+3
Philosophy	77	10	-1

$$X_{\text{sociology}} = z\sigma + \mu$$

$$X_{\text{communication}} = z\sigma + \mu$$

$$X_{\text{philosophy}} = z\sigma + \mu$$

Chapter 3.4 - z Scores and Percentiles

Converting z-scores to raw scores

$$X = z\sigma + \mu$$

Exam	Mean (μ)	Standard Deviation (σ)	Jennifer's Z-score
Sociology	90	5	0
Communication	72	5	+3
Philosophy	77	10	-1

$$X_{\text{sociology}} = z\sigma + \mu = (0)(5) + 90 = 90$$

$$X_{\text{communication}} = z\sigma + \mu = (+3)(5) + 72 = 87$$

$$X_{\text{philosophy}} = z\sigma + \mu = (-1)(10) + 77 = 67$$

Chapter 3.4 - z Scores and Percentiles

Review the significance of the Z-Score

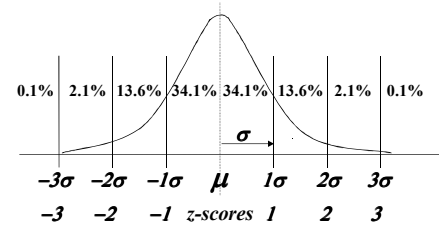
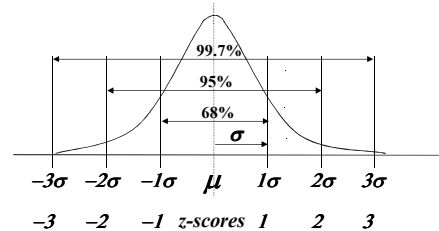

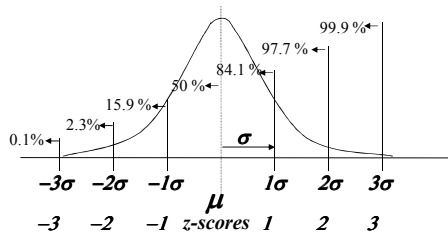
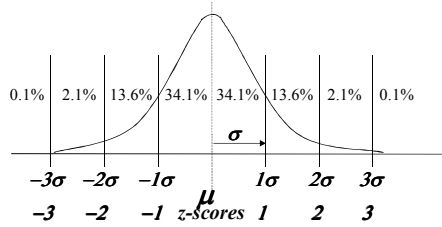

Page 150 / Prob 88

- a) Using the z-score formula, calculate the z-score for each raw score given in the table below.
b) Using the results of part a, which raw score would you consider to be a potential outlier? Explain.

	Raw	Mean	StdDev
i	45	60	9
ii	165	120	10
iii	590	400	150
iv	830	750	100
v	1470	1470	210

Page 150 / Prob 89

- a) Using the raw score formula, calculate the raw score for each z-score given in the table below.
b) Using the information in the table and the results of part a, state which raw score might be considered a potential outlier? Explain.

	Mean	Std Dev	z-score
i	120	50	+2.33
ii	500	160	-1.96
iii	75	25	+0.56
iv	450	90	-3.58
v	290	75	+1.65

Percentile Rank

Louisa

- 24 100
- 23 100
- 22 98
- 21 97
- 20 95
- 19 95
- 18 95
- 17 93
- 16 91
- 15 88
- 14 88
- 13 87
- 12 85
- 11 85
- 10 85
- 9 84
- 8 81
- 7 77
- 6 73
- 5 71
- 4 70
- 3 68
- 2 68
- 1 50

What is the rank of the student whose grade is 98?
Out of a class of 24 students,
21 students scored less than Louisa.

So the Percentile Rank of Louisa is...

$$\text{Percentile Rank of } X = \frac{[B+(1/2)E]}{N}(100)$$

where,

B = Number of scores less than X

E = Number of Scores equal to X

N = Total Number of Scores

$$\text{PR of } X = \frac{[21+(1/2)1]}{24}(100) = \frac{21.5}{24}(100) = 89.6\%$$

PR of X = 90% ...always expressed as a whole number

Box-and-Whisker Plot

A visual method of summarizing data with 5-numbers.
Smallest, 1st Quartile, Median, 3rd Quartile, and Largest

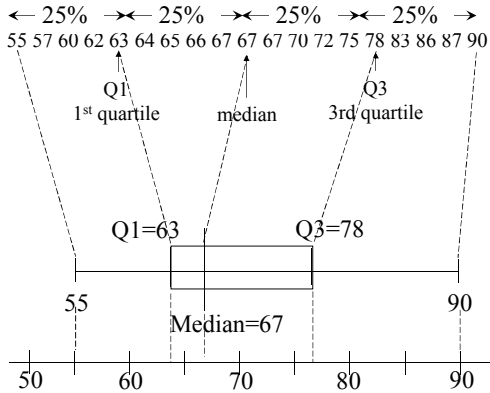

Box-and-Whisker Plot

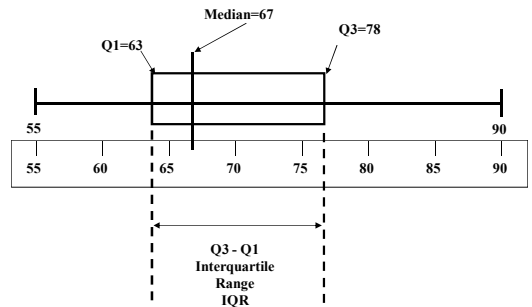

Box-and-Whisker Plot

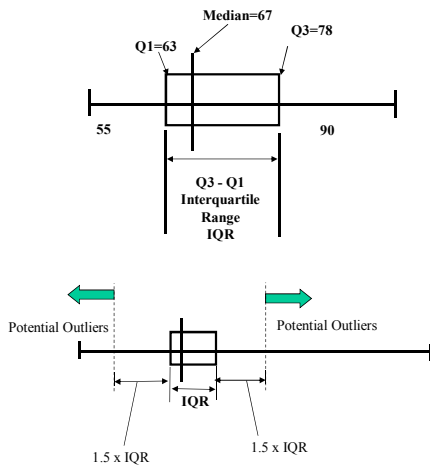

Box-and-Whisker Plot

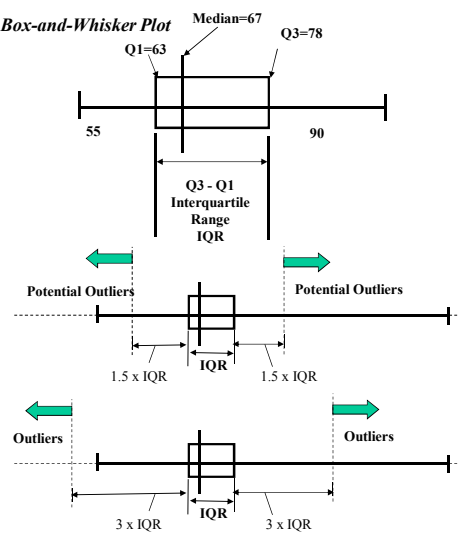

An outlier is
Any value $> Q3 + 3 \times IQR$
or
Any value $< Q1 - 3 \times IQR$

Chapter 3.5 - Box and Whisker Plot

Club 1	Club 2
44	40
50	37
48	39
44	35
42	35
47	41
49	37
50	37
39	34
45	38
32	40
47	35
40	38
38	34
41	35
43	37
40	34
37	40

Ages of 20 people accepted for membership in two clubs in a town.

5 Number Summaries

Min Q1 Med Q3 Max
 C1 32 40 43.5 47 50
 C2 34 35 37 39 41

Box and Whisker Plots

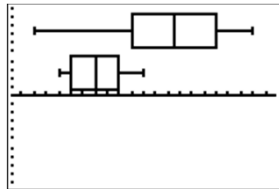

Chapter 3.5 - Box and Whisker Plot

Chapter Problems

Pg 150/96 On a box-and-whisker plot the middle 50% of the data fall between the ___ and ___ quartiles.

Pg 151/110

McGuire 3*, 49, 32, 33, 39, 22, 42, 9*, 9, 39, 52, 58, 70, 65
 Sosa 1*, 3*, 15, 10, 8, 33, 25, 36, 40, 36, 66, 63

Pg 152/128

375K	525K	425K	1486K	510K
655K	425K	490K	575K	505K

Pg 154/152

A beverage company's machine is designed to fill bottles of soda with 2 liters (67.6 oz.) Two 10 sample bottles are filled and measured.

Machine 1 67.8 67.5 67.7 67.6 67.9
 67.5 67.4 67.7 67.4 67.5

Machine 2 67.9 67.4 67.8 67.3 67.2
 67.9 67.3 67.8 67.6 67.8

Chapter 3.5 - Box and Whisker Plot

Chapter Problems (Cont'd)

Problem: What do I need to get on the last test to get an 80 average?
 My first three test are 76, 88, 50

Pg 157/192 A male is consider hypertensive if he has a blood pressure more than 2 std devs above the mean for his age group.

Age	Mean	Std Dev
18	121	8
25	125	8
35	127	9
45	130	13
60	142	14

Chapter 3.5 - Box and Whisker Plot

Chapter Problems (Cont'd)

Pg 158/204

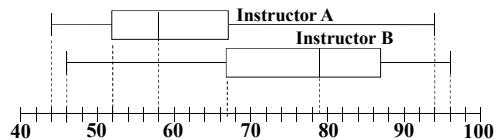

From the above plots, approximate for both instructors:

- 1st quartile test score
- 3rd quartile test score
- Median test score
- Smallest and largest test scores
- Interquartile range (IQR)
- Shape of the distribution
- Pct of test results to the left of the 3rd quartile
- Pct of test results to the right of the median
- Pct of test results between the 1st and 3rd quartiles

Which test is a better indicator of the top students in the class?